

A NEW APPROACH IN RADIO AND TELEVISION BROADCASTING OVER THE INTERNET

Borko Furht¹, Raymond Westwater², and Jeffrey Ice³

¹*Florida Atlantic University, Boca Raton, Florida*

²*Future Ware, Princeton, New Jersey*

³*Pipe Dream, West Palm Beach, Florida*

Abstract This paper presents several techniques for broadcasting multimedia data (audio and video) over the Internet. Internet broadcasting (also called webcasting) techniques have become very important in applications such as Internet (or Web) radio and television, real-time broadcasting of critical data (such as stock prices), distance learning, videoconferencing, and many others. We describe the current Internet broadcasting techniques including IP Unicast and IP Multicast, and we introduce a new technique referred to as IP Simulcast. The IP Simulcast approach is based on the hierarchical, binary structure of receivers, which at the same time become data senders or repeaters.

Keywords: Internet broadcasting, IP Unicast, IP Multicast, Internet radio, Internet television

For all correspondence contact:

Borko Furht
Department of Computer Science and Engineering
Florida Atlantic University
777 Glades Road
Boca Raton, Florida 33431, USA
Tel.: (561) 297-3486
Fax: (561) 297-2800
Email: borko@cse.fau.edu
Web: www.cse.fau.edu/~borko

1. INTRODUCTION

Internet broadcasting, referred as *webcasting*, is coming of age. Now, in addition to reprocessed audio or video that is transferred from radio or TV to the Internet, webcasting also means broadcasting new, original content, sometimes live, on the Web. Taking advantage of streaming audio and video technology, site producers can bring real-time sound and vision to the Web. With the present technology, to squeeze it through a 28.8 Kbps modem line, audio and video must be compressed almost to the breaking point, and that means plenty of people will find it's not worth hearing or viewing.

However, the problems have not stopped millions of people from downloading viewers and seeking out the webcasts. Listening to music or watching video straight off the Internet (Web) still creates a strong enough buzz that people overlook shortcomings like crackly audio, slow download times, and grainy pictures. As a consequence, a number of Internet radio stations have been created, which offer programs of commercial appeal to an international audience.

The Internet protocols used to transmit this data require individual connections to be formed between servers (or senders) and their clients (receivers). The proliferation of such connections is quite expensive, because it consumes both a very high network bandwidth and processing power at the server. Well-known Internet radio stations have developed their solutions around networks of expensive servers at ever-escalating expense.

And although we are still in the early stages of webcasting, one can already foresee what the Internet will offer a few years down the line: clear, crisp, audio and full-screen, high-quality, on-demand video. Pipe Dream, Inc. has developed a revolutionary technology, which will provide all these required features for Internet webcasting. This innovative technology consists of:

- IP Simulcast – a new Internet broadcast protocol, which provides inexpensive, efficient, and reliable audio and video broadcasting,
- New audio and video compression algorithms, which allow real-time audio and video transmission of data at very low bit rates (1/3 of the modem bit rate) and with high quality.

2. PRESENT APPROACHES IN DATA BROADCASTING OVER THE INTERNET

There are three fundamental types for transmitting data on the Internet, as illustrated in Figure 1:

- IP Unicast,
- IP Broadcast, and
- IP Multicast.

IP Unicast transmission is designed to transmit data (or a packet) from a sender to a single receiver, as shown in Figure 1a. *IP Broadcast* transmission is used to send data from a sender to an entire subnetwork, as illustrated in Figure 1b. *IP Multicast* transmission is designed to enable the delivery of data from a sender to a set of receivers that have been configured as members of a multicast group in various scattered subnetworks, as shown in Figure 1c.

For radio and television broadcast applications, *one-to-many data distribution model* is required. In one-to-many data distribution model, the data flow is from a single sender to many receivers simultaneously, but not the whole subnetwork. Therefore, present audio and

television broadcast applications typically use IP Unicast transmission, or they may also use IP Multicast transmission.

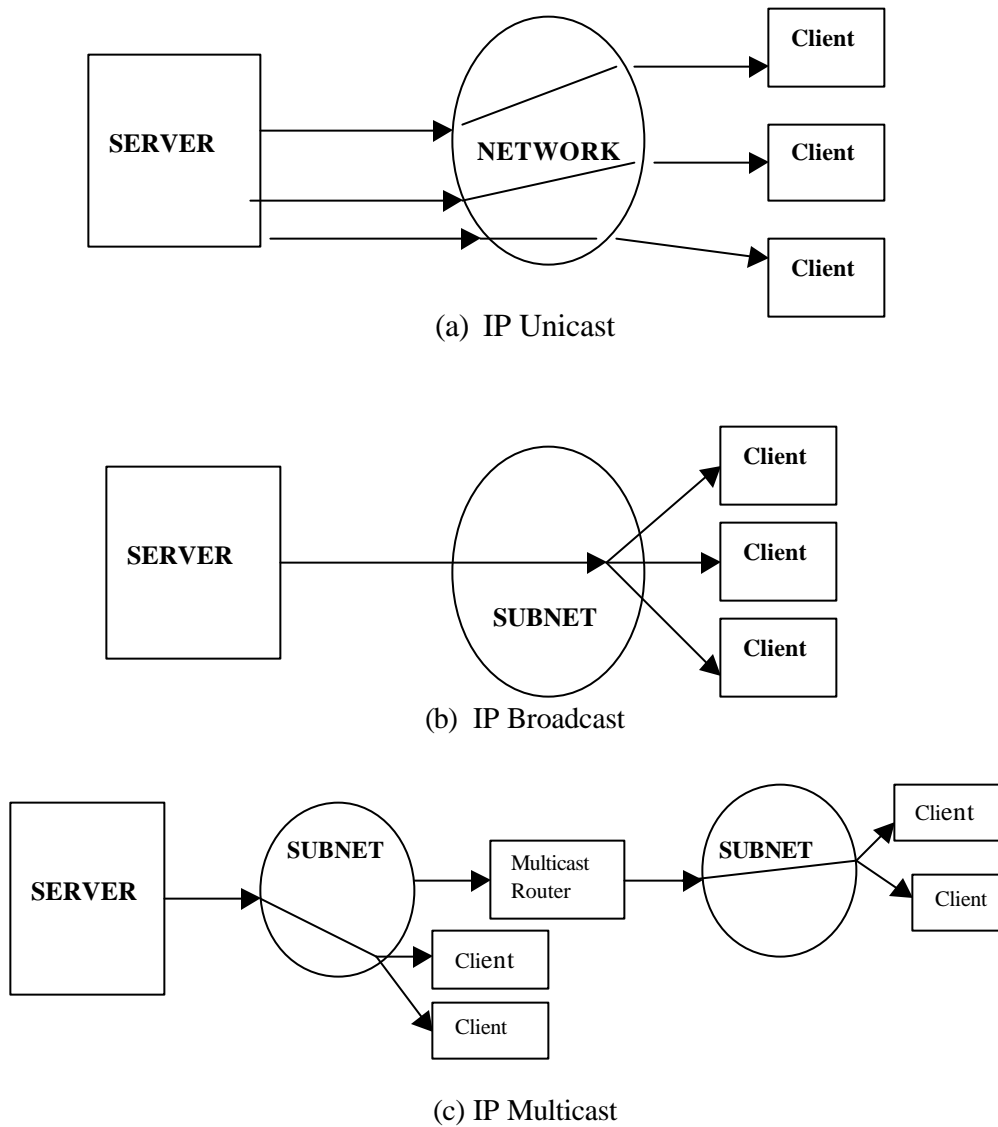

Figure 1. Present approaches in data transmission on the Internet.
(a) IP Unicast, (b) IP Broadcast, (c) IP Multicast.

2.1 IP Unicast

Many current radio and television Internet broadcast applications use unicast data transmission for data distribution. In this case, connection-oriented stream transports are used to distribute data to each receiver individually. These applications duplicate the data they send to each receiver and use unicast transmission to each receiver. As a result of this duplication these applications are far from optimal due to the following reasons:

- (a) Network bandwidth is wasted,

- (b) They cannot scale to service increasing numbers of receivers,
- (c) They cannot distribute data in a timely manner, since the delivery to each host has to be serialized.

2.2 IP Multicast

IP Multicast transmission provides sending the data from a sender to multiple receivers, but unlike in IP Unicast, the number of identical copies that are sent is minimized. All receivers are configured as members of the same multicast group. The sender sends an IP packet to a multicast address, and lets the network forward a copy of the packet to each group of hosts. Multicast is not connection oriented; the sender sends data to multiple receivers over UDP (User Data Protocol). The UDP protocol, unlike TCP, makes only a “best effort” to deliver data. If a transmission error occurs, the packet is discarded [1,2,3].

The IP Multicast protocol is implemented in the routers of a network, rather than in the server. The routers in the network automatically make a copy of the multicast packet for each destination receiver. In such a way, the number of excess copies transmitted to any particular subnet is minimized, and therefore IP Multicast is much more efficient than IP Unicast requiring much smaller server bandwidth.

The basic service of IP Multicast is unreliable unicast transmission of datagrams, which is only suitable for applications geared toward performance rather than reliability [1]. Error recovery can be done by sending requests to the server (sender). This will require a more complex scheme and a higher network bandwidth.

In addition, IP Multicast routing requires special IP Multicast routers. All intermediate routers between the sender and receivers must be IP Multicast capable, as illustrated in Figure 2.

In many cases, firewalls in the network may need to be reconfigured to permit IP Multicast traffic.

At the receiver (client) node, a number of requirements exist in order to receive IP Multicast protocol, such as:

- Support for IP Multicast transmission and reception in the TCP/IP protocol stack,
- Software that support IGMP to communicate requests to join a multicast network traffic, and
- Network interface card, which efficiently filter for LAN data link layer addresses mapped from n addresses.

Multicast Routing

Routing of multicast traffic is a complex problem, because a multicast address identifies a particular transmission session, rather than a specific physical destination. Some new techniques have been developed to address the problem of efficiently routing multicast traffic [7]. Since the number of receivers for a multicast session can potentially be quite large, the source should not need to know all the relevant addresses. Instead the network routers must somehow be able to translate multicast addresses into host addresses. To avoid duplication of effort, a single router is selected as the designated router for each physical network. For efficient transmission, designated routers construct a spanning tree that connects all members of an IP Multicast group, as illustrated in Figure 3. A spanning tree has just enough connectivity so that there is only one path between every pair of routers.

IP Multicast routing algorithms and protocols use two approaches:

Dense-mode routing protocol assumes that the multicast group members are densely distributed throughout the network. It relies on periodic flooding of the network with multicast traffic to set up and maintain the spanning tree.

Sparse-mode routing protocol assumes that the multicast group members are sparsely distributed throughout the network. In this case, flooding would waste network bandwidth and hence could cause serious performance problems. Therefore, it uses more selective techniques to set up and maintain multicast trees.

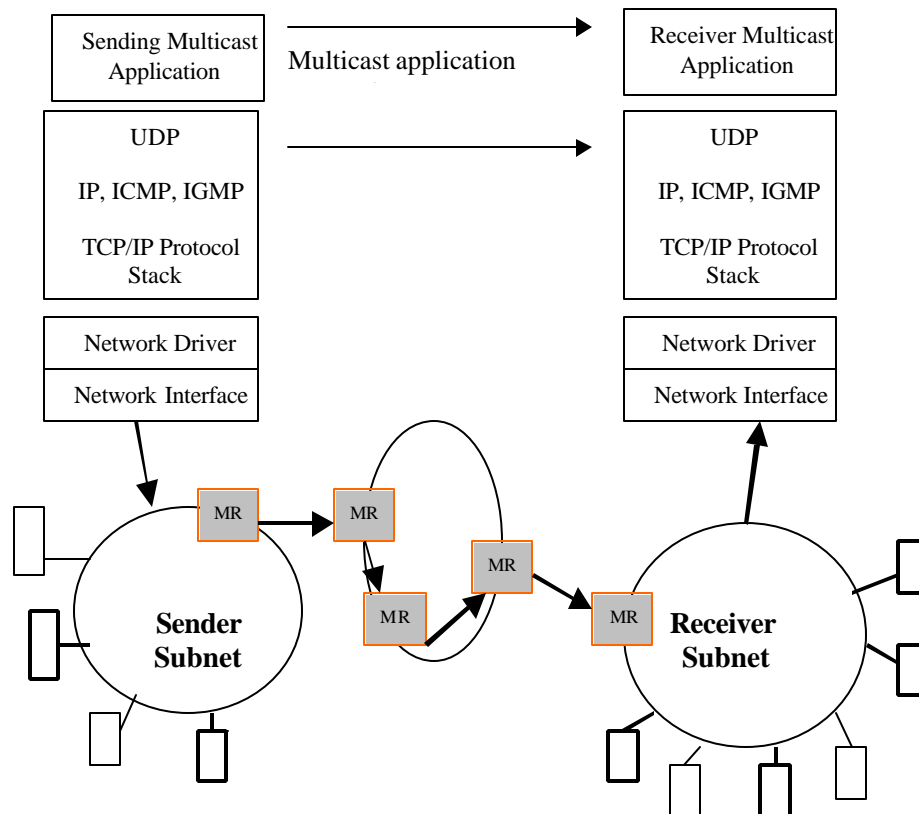

MR is a multicast-enabled

Figure 2. The network with IP Multicast-enabled components.

In summary, IP Multicast provides much more efficient one-to-many data distribution than IP Unicast, but there are a number of yet unsolved issues:

1. Network issues related to all intermediate routers that must be IP Multicast-enabled and the reconfiguration of the firewall,
2. Issues related to the reliability and error control, and

- Requirements related to receivers, which need a special network card and software that supports IP Multicast.

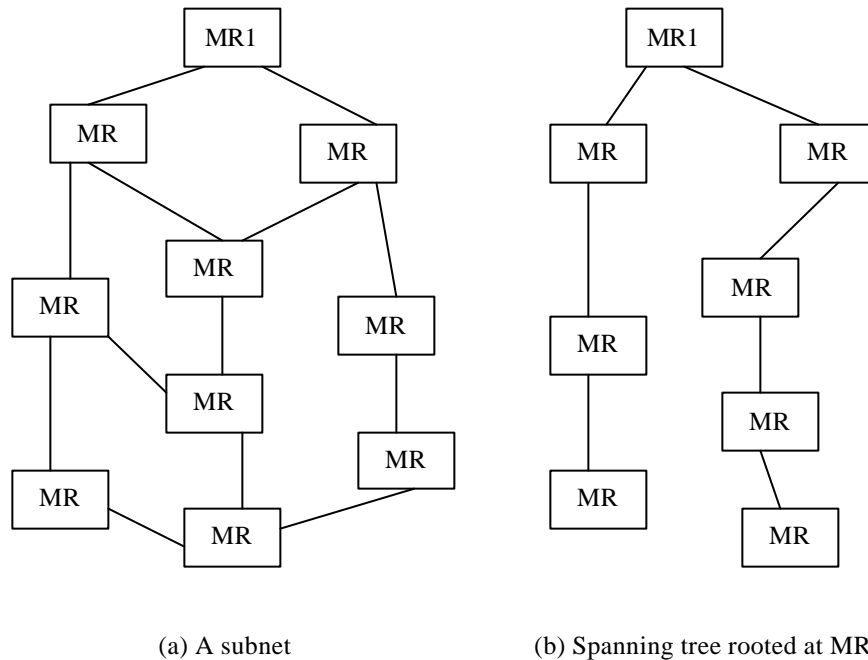

Figure 3. Examples of spanning trees in IP Multicast.

3. INTERNET BROADCAST BASED ON IP SIMULCAST

Pipe Dream has invented a new technique, referred to as IP Simulcast, for transmitting data over the Internet from a sender simultaneously to multiple receivers. In this section, we describe basic principles of IP Simulcast as well as technical details of the IP Simulcast protocol. We also compare IP Simulcast with the other approaches including IP Unicast and IP Multicast.

3.1 Basic Principles of IP Simulcast

IP Simulcast is an innovative solution for the Internet broadcasting, which shows significant advantages over the existing techniques including IP Unicast and IP Multicast. It resolves all the issues and problems involved in the implementation of the IP Multicast, discussed in the previous paragraph.

Similarly to IP Multicast, IP Simulcast reduces the server (or sender) overhead by distributing the load to each client (receiver). Each receiver becomes a repeater, which rebroadcasts its received content to two child receivers (repeaters), forming a broadcast pyramid, as illustrated in Figure 4.

In such a way the needed network bandwidth for the server/sender is significantly reduced, because the server sends just one copy of the data, which is then further re-broadcast by the receivers/repeaters. Thus, the cost of service provision is borne by the receivers (rather than the sender), who have typically paid for the fixed bandwidth that is often not used.

In this way, the IP Simulcast concept provides broadcast functionality at a lower cost than IP Multicast does. Unlike IP Multicast, which requires special routers for its implementation as well as several additional requirements, IP Simulcast does not require any special requirements for its implementation.

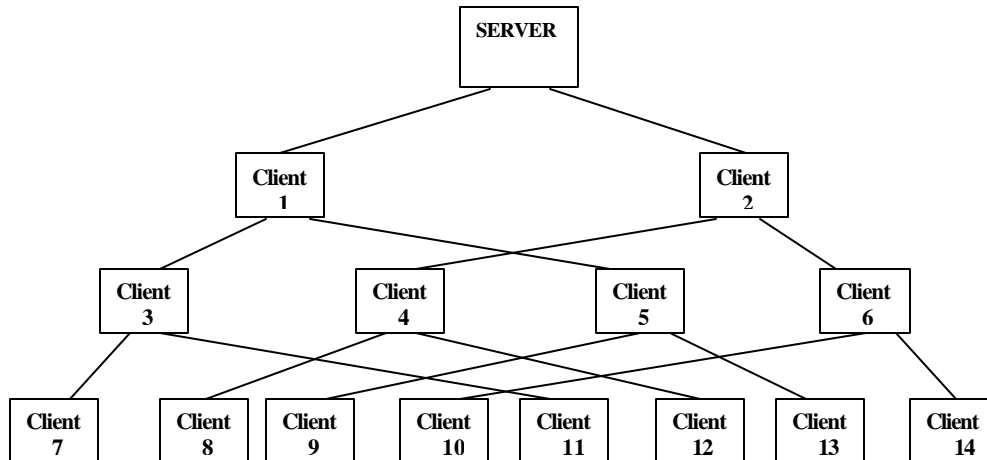

Figure 4. Broadcast pyramid applied in IP Simulcast.

The number of clients in the IP Simulcast pyramid grows as a binary tree. For a pyramid with 1 tree level, the number of clients is 2, for a pyramid with 2 levels, the number of clients is 6, and so on. The number of clients in the n^{th} level is 2^n . For example, for a broadcast system with 10 levels, the number of clients in the last level is $2^{10}=1,024$, and the total number of clients in the pyramid is then $1024+1022=2,046$.

The repeater/receiver performs conventional client functions, including error recovery and detection of the loss connection. As a consequence, IP Simulcast provides guaranteed delivery of packets, which is not the case of IP Multicast. As we mentioned in the previous paragraph, IP Multicast services make no provision for error recovery. The lost packets must be either ignored, or recovered from the server at the cost of the increased server bandwidth.

IP Simulcast uses a radically different model of digital broadcast, referred to as *repeater-server model*. In the repeater-server model, the server manages and controls the interconnection of repeaters. While the server may be fairly similar to a conventional server, the repeater contains server functions in addition to conventional client functions. In essence, each repeater not only plays the data stream back to its audience, but also transmits the data stream to two other repeaters (see Figure 4).

The fundamental part of the IP Simulcast protocol is its specification of the repeater-server relationship. The IP Simulcast server/sender performs two fundamental functions, as any conventional server:

- Transmission of the broadcast stream, and
- Forming connections, which interconnects repeaters/receivers and maintains the Simulcast pyramid.

Repeaters are composed of two subsystems:

1. Repeater-client subsystem, and
2. Repeater-sender subsystem.

The repeater-client subsystem receives a broadcast stream and plays back the stream interactively to its audience. In addition, the repeater-client subsystem performs traditional client functions including connection, receipt of data, and buffer management, decompression of multimedia data, error recovery, and detection of the loss connection.

The repeater-sender subsystem rebroadcasts the data that the repeater-sender subsystem has received. It also performs error retransmission.

3.2 The IP Simulcast Protocol

As illustrated in Figure 4, IP Simulcast is based on the new repeater-server model. The server sends the data only to two repeaters/receivers, and then the packets are rebroadcast by each level of repeaters to the next level. In such a way, a pyramid network is built, which is managed and controlled by the server. In addition, in order to assure a reliable data transmission, retransmission of lost packets or packets with errors is requested through secondary feeds (dashed lines in Figure 5).

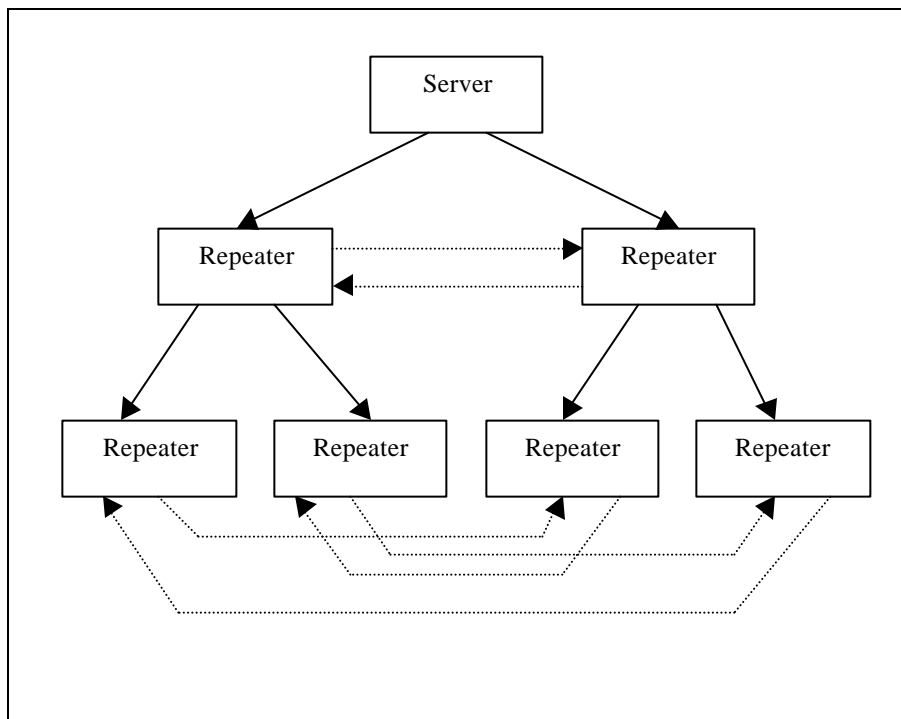

Figure 5. IP Simulcast repeater-server relationship.
Retransmission of packets is requested through secondary feeds (dashed lines).

The server functions include:

- *Digitization of the program source.* A typical source program might include analog audio and analog video. These analog program sources are digitized into streams of time-varying data.

- *Synchronization of the digital source.* Streams of time-varying data may come from various sources: digitization of analog sources, stored compressed data on disk, digital data from animation programs, authoring programs, or other sources. Source programs may be interrupted, overlaid, or otherwise synchronized with advertising spots, source programs may be scheduled throughout the day, etc. The various sources of digital data must be synchronized and time-stamped for playback.
- *Compression of the source.* Each stream of time-varying digital data may be compressed to reduce its size and transmission time. The compression technique is a trade-off amongst various factors including compression ratio, perceived quality, complexity of compression and decompression, scalability, and noise immunity.
- *Collection of the compressed source into transmission packets.* IP transmission is a packet-based protocol. The data is collected into IP packets in preparation for transmission. Compressed data may be represented by several alternative packetization schemes to adapt to different speed transmission lines or computers of different power. Each of these packetization schemes could be used to feed an alternate pyramid of repeaters.
- *Transmission of compressed source transmission packets.* Two feeds are supported, each to be received and retransmitted by its destination repeater.
- *Connection of repeaters.* Each repeater sends a request to the server asking to be serviced with the transmission stream. The server responds by selecting an available repeater to be the requesting repeater's source. The transmission stream is then fed to the requesting repeater. The server also selects a secondary feed for the requesting repeater. Error retransmission is accomplished over this secondary feed.
- *Collection of statistics.* The server monitors the construction and breaking of connections.

Each repeater-client has responsibility for collecting the transmitted data streams and playing them back to its audience. The repeater-clients' functions include:

- *Establishment of connections.* The repeater-client issues a connection request to the server. The server will establish an individual connection to the repeater-client.
- *Reconnection.* The client must determine if a connection is broken, and attempt reconnection.
- *Caching of packets.* Received packets must be sequenced and cached in order to locate missing packets.
- *Retransmission requests.* Requests are issued to the repeater-client's secondary feed to request retransmission of missing packets.
- *Error recovery.* In the case that a packet cannot be recovered, the repeater-client must perform some recovery action (play silence, replay the last packet, degrade quality, etc.)
- *Decompression of received data stream.* The received data is decompressed in anticipation of playback.
- *Playback of data streams.* The decompressed data is played back to the repeater-client's audience.

- *Synchronization with the server.* The playback rate must match the server's capture rate to avoid overflow or starvation of the repeater-client's buffers. The repeater-client must be able to adapt to the small differences in playback rate that are bound to exist.

The repeater-transmitter performs some conventional server functions:

- *Transmission of compressed source transmission packets.* Two feeds are supported, each to be received and retransmitted by its destination repeater.
- *Retransmission of error packets.* A secondary feed is supported by each repeater-transmitter. On request, a missed packet is retransmitted to the destination of the secondary feed.

The broadcast system is subdivided into fractional streams for transmission purposes. Repeaters for each fractional stream are organized into a binary tree, propagating the fractional stream through all repeaters. Fractional streams are collected into a single stream by each repeater. The collection of these fractional streams causes a superposition of the binary tree into a single "bush" that represents the transmission of the full system. The topology of the superposition is chosen such that the two levels of a fractional tree are separated by one-half the width of the stage in the tree. This topology ensures that no repeater is starved by the failure of a single feeding repeater. Figure 6 shows feeding a stage of length 8 with two fractional streams.

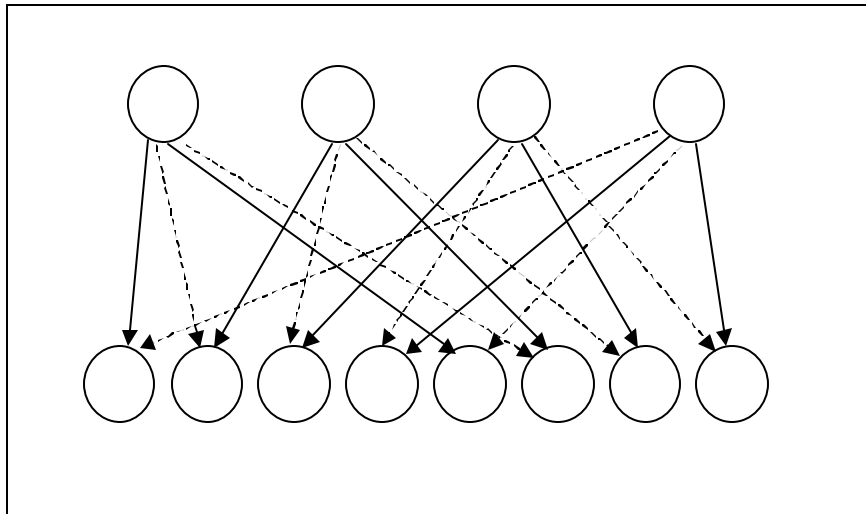

Figure 6. Feeding a stage of length 8 with two fractional streams.

Each repeater collects packets into a buffer. The buffer is used to compensate jitter delays. Additional buffering is introduced to perform error recovery. After the jitter and error delay has played out, the received packets are broadcast to the next level.

Error recovery is composed of two distinct phases: error recovery and retry service. During the error recovery interval, queries are made in the round-robin fashion to repeaters in the previous stage. During the retry service period, retry requests from the subsequent stage are serviced. Figure 7 illustrates the timing for the received packets, which are buffered for error recovery and playback.

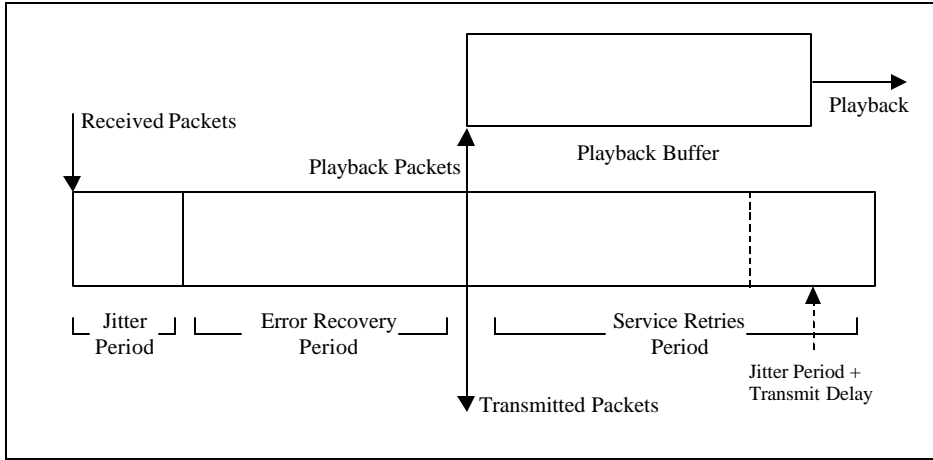

Figure 7. Timing diagram – received packets are buffered for error recovery and playback.

Transmitted samples are placed in a playback buffer. Playback is synchronized to the rate at which packets are received to avoid playback buffer overflow and underflow.

An unassigned repeater issues a connection request to the server-administrator to join the broadcast. The server-administrator acknowledges the request and queues the repeater for connection. If the repeater has not been connected by the time its queue entry times out, the server-administrator issues fractional feed requests to the last complete stage, starting a feed to the repeater.

When a repeater/receiver wants to leave the broadcast, it issues a disconnection request to the server. If the queue of the repeaters waiting for connection is not empty, a repeater is selected from the queue, and the server issues fractional feed requests to the parents of the terminating repeater. On the other hand, if the repeater connection queue is empty, the oldest node on the bottom stage is used as the replacement node. In the event of node failure, the children of the node report the failure to the server.

3.3 Analysis of IP Simulcast Algorithm

In this section we present a mathematical analysis of the IP Simulcast algorithm in order to get the quantitative values for the buffers in receivers/repeaters nodes needed:

- (a) to reduce the effect of jitter delay, and
- (b) to minimize the number of lost packets.

We begin with the assumption that the stream traffic is broadcast to all nodes of the tree. Transmission packets are equal in size, and require time τ to transmit. The packet transmission rate is p packets per second. Transit time T from node to node has the same mean time μ_T irrespective of the node pairs. Jitter time (J_T) is the variation in transit times from the mean and is simplistically modeled as packet interarrival time, Poisson distributed with packet arrival rate $p=1/\sigma_T$. The probability density function for jitter time J_T can be expressed as:

$$f_J(t) = pe^{-pt}$$

The probability that transit time lies in the interval (t0, t1) is then:

$$P[t_0 < t < t_1] = m_T - s_T + \int_{t_0 - m_T + s_T}^{t_1 - m_T + s_T} p e^{-pt} dt$$

Transmission error is modeled as dropped packets occurring at random periods, Poisson distributed with packet dropping rate $p_d = 1/\sigma_T$. The probability density function for transmission error is given as:

$$f_E(t) = p_d e^{-p_d t}$$

Jitter Buffering

Jitter buffering is used to reduce the effect of jitter delay. Jitter buffers are chosen sufficiently large to give desired confidence that a missing packet has been lost, and is not simply delayed. The probability that the packet interarrival time does not exceed jitter buffer time I (i.e., the confidence that the packet has been lost to error) is:

$$P[t < I] = \int_0^I p e^{-pt} dt$$

Solving for I (jitter buffer time) gives:

$$\begin{aligned} I &= -s_T \ln(1 - P[t < I]) \\ &= 1 - e^{-pI} \end{aligned}$$

Jitter increases as packets propagate down the pyramid. A pyramid of N nodes has $n = \log_2(N)$ levels, and the PDF for jitter delay at the nth stage is:

$$f_{J_n}(t) = n p e^{-npt}$$

Choice of I_n , the amount of jitter buffer time needed to develop the confidence level $P[t < I_n]$ that a packet has been lost is:

$$I = -n s_T \ln(1 - P[t < I_n])$$

The required jitter buffer size grows linearly with the depth of the tree, as illustrated in Figure 8.

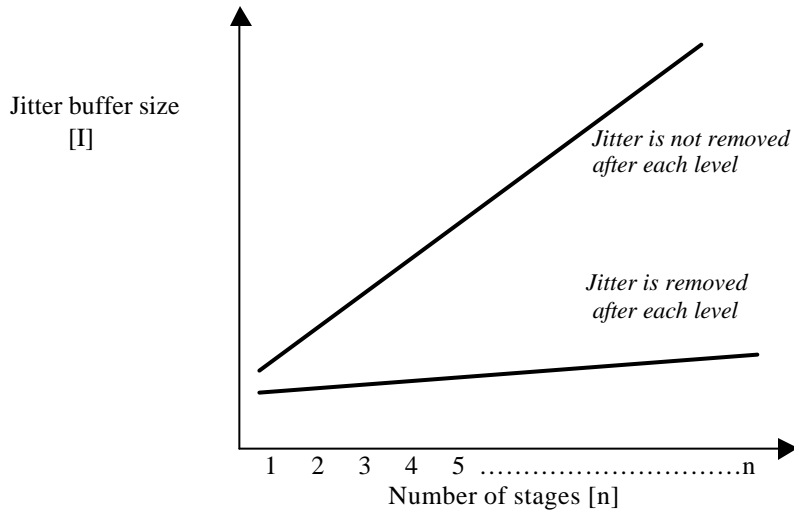

Figure 8. Jitter buffer size as a function of number of stages in the tree.

An alternative formulation is derived by assuming that transmission to the next level takes place after jitter buffering; i.e., jitter is removed at each level by introducing buffered delay in retransmission. If the desired jitter buffering confidence level at stage n is C ,

$$C = P[t < I]^n = (1 - e^{-pt})^n$$

Solving for I gives:

$$I = -s_T \ln(1 - \sqrt[n]{C})$$

In this case the required buffering at the next stage slightly increases with the depth of the tree, as shown in Figure 8.

Retry Buffering

Retry buffering is used to minimize the number of lost packets. Lost packets are recovered by issuing retry commands to the transmitter. This is done after the jitter buffer period, and the packet should be received after round-trip transmission time plus round-trip jitter buffering. This process may be repeated until a desired confidence level of packet receipt is assured. Let denote the desired buffer length be B . Then, the probability that the packet arrival time does not exceed retry buffer time is given as:

$$P[t < nB] = \left[\int_0^B s_E e^{-s_E t} dt \right]^n = 1 - e^{-s_E n B}$$

where $\sigma_E = 1/p_E$, where p_E is the error packet rate.

Solving for n gives:

$$n = \frac{-\ln(1 - P[t < nB])}{s_E B}$$

We can conclude that transmission errors accumulate at each stage, but the accumulation at each stage has a second-order dependency on the stage before.

The probability that a packet is not received at the first stage after m retry periods is:

$$P[t < T] = \left[\int_0^T s_E e^{-s_E t} dt \right] \prod_2^m \left[\int_0^T 2s_E e^{-2s_E t} dt \right]$$

where the factor of 2 is introduced to account for errors in transmitting the retry request. The probability that a packet is not received at the n^{th} stage is:

$$\begin{aligned} P[t < T] &= \left[\int_0^T n s_E e^{-n s_E t} dt \right] \prod_2^m \left\{ \int_0^T (n+1) s_E e^{-(n+1) s_E t} dt \right\} \\ &= \left[1 - e^{-n s_E T} \right] \left[1 - e^{-(n+1) s_E T} \right]^{m-1} \approx \left[1 - e^{-n s_E T} \right]^m \end{aligned}$$

Solving for m (retry periods) gives:

$$m = \frac{\ln(P[t, T])}{\ln[1 - e^{-n s_E T}]}$$

Figure 9 shows the packet drop rate as a function of number of levels in the Simulcast pyramid for various number of retries (0 to 4). The system packet drop rate in this experiment is 25%, which means that at the first level 75% of packets will be received correctly, and 25% will be dropped due to transmission errors. As we can see from Figure 9, with several retries the transmission becomes much more reliable, so that in the case of 4 retries the packet drop rate at high levels is very low.

4. COMPARISON WITH OTHER APPROACHES

In this section we compare the IP Simulcast approach for audio broadcasting with the UP Unicast and UP Multicast systems. We assume an audio broadcast system, which continuously broadcast 16 Kbps to a maximum of 10,000 clients/receivers.

For the comparison, we used the following assumptions:

- When calculating the server bandwidth, we assumed 1% error retransmission and we ignored control overhead. The server bandwidth for IP Multicast reflects error retransmission from the server.
- Bandwidth cost is calculated assuming \$1,000 per T1 connection per month (1.5 Mbps).
- In the case of IP Simulcast, only one server is used to manage and control the broadcasting pyramid and to compress audio. The server cost is \$5,000.
- In the case of IP Unicast, 16 servers are used each at cost of \$3,000.
- In the case of IP Multicast, one server is used to support transmission to the network and one to service error retry requests (total cost \$8,000).

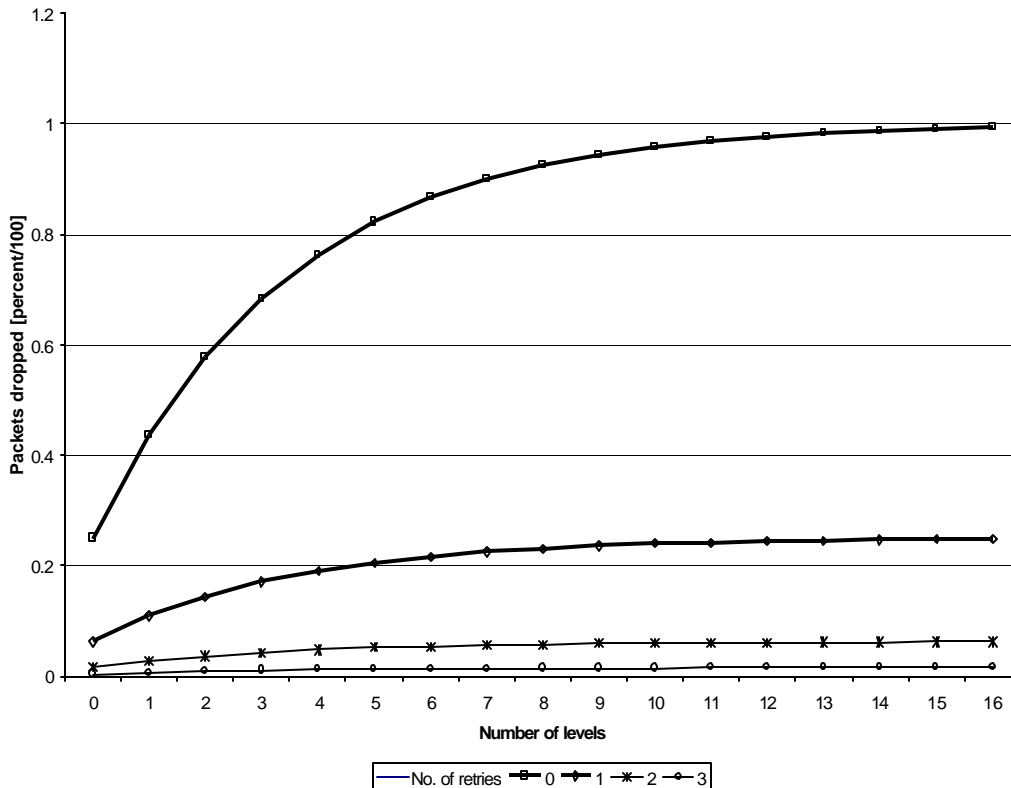

Figure 9. The packet drop rate as a function of number of levels in the IP Simulcast pyramid.

Table 1 compares these three approaches.

In summary, IP Simulcast-based solution for Internet broadcasting provides a number of advantages compared to existing technologies including IP Unicast and IP Multicast. These advantages can be summarized as follows:

- **Lower cost.** Due to inexpensive server and network requirements, IP Simulcast-based solution offers much lower price than the other solutions.
- **Better flexibility.** IP Simulcast-based solution provides a general solution and its broadcasts are received regardless of the physical solution, medium, noise of the connection, or network provider of the receiver.

- **Higher quality.** Pipe Dream's solution is designed to function in the unreliable Internet environment, and provides built-in error recovery and quality control, while the other solutions are not reliable.

FEATURES	IP UNICAST	IP MULTICAST	IP SIMULCAST
Server Bandwidth	162 Mbps	1.62 Mbps	16.2 Kbps
Bandwidth Cost	\$100,000 per month	\$20,000 per month	\$100 per month
Error Recovery	By server	By server	By client
Initial Server Cost	\$53,000	\$8,000	\$5,000
Client Reachability	Any IP address	Only clients in proprietary network	Any IP address
Implementation Issues	Cannot scale to serve increasing number of clients	Requires all intermediate IP Multicast routers Requires special network card and software which supports IP Multicast	Easy to implement Does not require any special cards or routers

Table 1. Comparison of features of various techniques for audio broadcasting.

5. POTENTIAL APPLICATIONS

Due to its simplicity, easy to implement, efficiency, and inexpensive initial cost for the server and network bandwidth, IP Simulcast is a very efficient and inexpensive solution for many current and potential webcast-based applications. IP Simulcast is well suited for **radio and television broadcasting**, and these are the first two applications created by Pipe Dream, Inc.

However, the other potential applications include:

- Distance learning,
- Electronic software distribution including software update,
- Real-time broadcasting of critical data (like stock prices),
- Database replication and file transfer,
- Videoconferencing and many others.

We will briefly analyze the market for radio broadcasting on the Internet. The radio on the Internet application offers very attractive features to the audience, such as scheduled programs, supplementary data on the scheduled programs, as well as interactive services. Thus, more than 27% of America's 11,000 radio stations already have Web sites.

The number of radio stations offering on-line radio programs has also increased in the last several years, from 50 (in 1995) to 741 (end of 1997), of which 341 are in U.S. The MIT forecasts that 1,500 to 2,000 stations will be webcasting by the end of 1998.

The following elements comprise the attraction of live radio or video broadcast:

- The Internet is the only medium that enables a radio broadcast to be audible worldwide. The prospect of global recognition is a highly motivating element.

- The access to an innovative transmission channel will improve the coverage of their audience. Indeed, 60% of on-line radio listeners live in the radio's emission zone. Thus, employees can now listen to their radio in the workplace, a phenomenon that is developing in the U.S.
- The increase in the audience size and the increase in their listening times will increase the advertisement prices.
- The addition of real-time broadcasting radio to the Web site will also increase the number of connections to the Internet site, and consequently the advertising income linked to it.

Based on IP Simulcast protocol, Pipe Dream has developed two applications – SimulSays for radio broadcasting and SimulSees for television broadcasting. The Pipe Dream's broadcasting systems are shown in Figure 10.

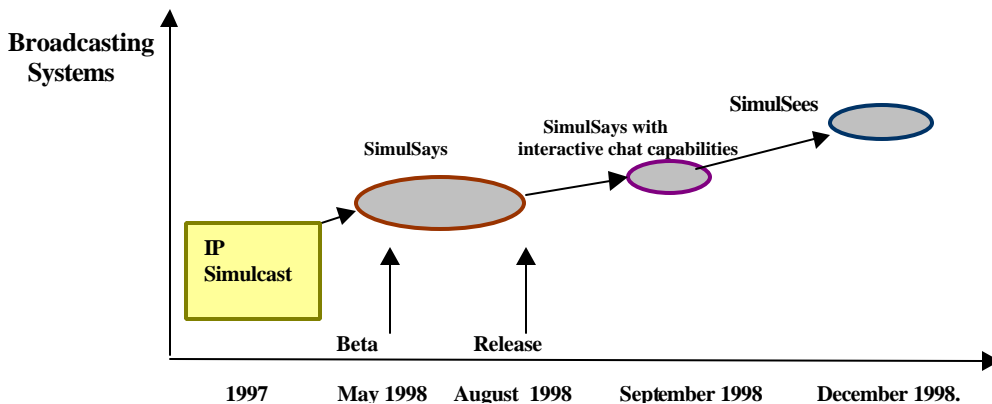

Figure 10. Pipe Dream's broadcasting systems.

SimulSays is the application, which uses IP Simulcast protocol to allow radio broadcasters to broadcast (webcast) radio programs to an unlimited number of clients using a simple and inexpensive server and a small server bandwidth. Thus, the broadcaster needs a very low initial cost in order to begin broadcasting radio programs. Besides the IP Simulcast protocol, SimulSays applies an innovative audio compression technique, which is capable of compressing audio while maintaining its high quality. SimulSays also includes the banner function. The banner allows broadcasting advertising messages as well as transmission and display of supplementary data, such as maps, telephone numbers, election graphs, dates for various events, and many others.

The Pipe Dream's *Radio Player* can be downloaded from the Web site <http://www.pipedream.com>. There is also a *Radio Guide*, linked to the Pipe Dream's radio player, which can be used to listen to test radio stations, broadcast from the Pipe Dream server. Radio Player and Radio Guide are shown in Figure 11.

SimulSays with chat function is an upgraded SimulSays application, which provides interactivity among the receivers/clients via a chatboard. This application will enrich radio transmission and make it very attractive due to interactivity. The clients, who are involved in listening to radio programs, can interactively exchange messages among themselves.

SimulSees is also using IP Simulcast protocol to provide television broadcasters with an efficient and inexpensive solution for broadcasting (webcasting) television programs to large number of clients. Similarly, the initial cost for broadcasters includes a simple and inexpensive server and a small network bandwidth. Besides IP Simulcast technology, SimulSays uses a new real-time video compression algorithm, which enables live video webcasting at low bit rates.



Figure 11. Pipe Dreams' Radio Player and Radio Guide using the IP Simulcast broadcasting technique.

6. CONCLUSIONS

In this paper we presented several techniques for multimedia broadcasting over the Internet: IP Unicast, IP Multicast, and the new technique IP Simulcast. In summary, the IP Simulcast protocol is the superior technique for real-time data broadcasting on the Internet. It enables an efficient coverage of "big events" on the Web, without additional investment to the server and network bandwidth. The number of connections on the Internet, covered by IP Simulcast, is practically unlimited. Coupled with efficient audio and video compression techniques, IP Simulcast offers an attractive solution for a number of broadcast applications on the Internet including radio and television broadcast, real-time broadcasting of critical data, distance learning, and many others.

References

1. Semeria, C. and Maufer, T. (1996): "Introduction to IP Multicast Routing", <http://www.ipmulticast.com/community/semeria.html>
2. C. Huitema, C. (1995): "Routing in the Internet", Prentice Hall, Inc., Englewood Cliffs, New Jersey.
3. "Writing IP Multicast-Enabled Applications", Stardust Technologies, <http://www.ipmulticast.com/community/whitepapers/ipmcapps.html>
4. Bremsler, W. (1998): "Pump Up the Volume", in: "Computerlife", pp. 91.
5. Macedonia, M.R. and Brutzman, D.P. (1994): "MBone Provides Audio and Video Across the Internet", in: "IEEE Computer", pp. 30-36.
6. Kumar, V. (1996): "MBONE: Interactive Media and the Internet", New Riden, 1996.
7. Johnson, V. and Johnson, M.: "How IP Multicast Work", Stardust Technologies, <http://www.ipmulticast.com/community/whitepapers/howipmcworks.html>
8. Johnson, V., Johnson, M., and Miller, K.: "Implementing IP Multicast in Different Network Infrastructures", Stardust Technologies, <http://www.ipmulticast.com/community/whitepapers/netinfra.html>
9. Ice, J., "Method for Connecting Systems Into a Broadcast Network", patent pending.
10. Ice, J. and Westwater, R.: "System and Method for Improved Quality Compression and Decompression of Speech Signals", patent pending.
11. Westwater, R. and B. Furht, B. (1996): "The XYZ Algorithm for Real-Time Compression of Full-Motion Video", in: "Journal of Real-Time Imaging", 2, 1, pp. 19-34.
12. Hardman, V., Sasse, M.A., and Kouvelas, I. (1998): "Successful Multiparty Audio Communication", in: "Communications of the ACM", 41, 5, pp. 74-80.